

HushFrame Decoupling Connector Installation Guide

www.hushframe.com
sales@hushframe.com

55 Woodrock Rd, Bay 9
Weymouth, MA 02189
+1 (800) 809-HUSH
(4874)



CAUTION: Before you begin, read these instructions in their entirety

HushFrame will not be held responsible for any issues arising from failure to strictly adhere to the installation instructions contained herein

Failure to follow these instructions will result in installation failure, and it's very easy to succeed

HushFrame decoupling isn't rocket science, but it is science, and requires careful attention to a few simple things

Proper installation will result in the highest performing acoustic isolation available, no other decoupler can do what HushFrame decoupling connectors can do, simply and economically

Designate one person on the building team to read this guide in its entirety and accept the role of installation supervisor

Do not begin the attachment of HushFrame until the installation supervisor is prepared and gives the OK



Description of the decoupling connector

The decoupling connectors are deceptively simple devices... they consist of two (2) wooden mounts separated and connected by a vibration-isolating silicone core which provides the decoupling. The longer and thinner STRUCTURE MOUNT attaches to the framing, typically studs or joists. The shorter and thicker face of the FURRING MOUNT is where the furring attaches—typically wood strapping, but metal hat channel is also acceptable.

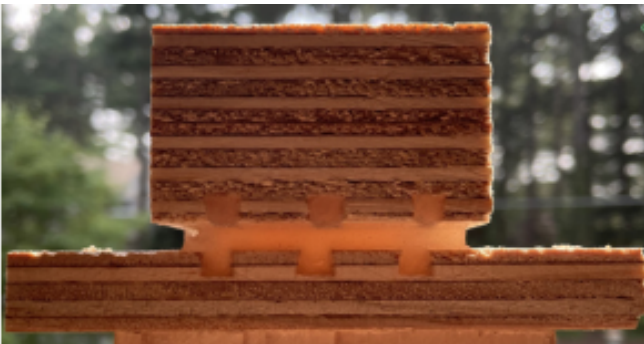

Here you see the translucence of the Vi-Bridge pure silicone core that kills noise energy more effectively than any other decoupling product, say goodbye to low frequency rumble.

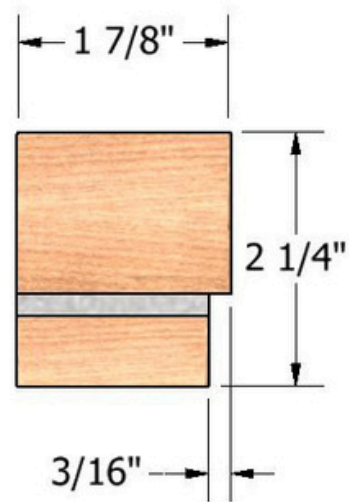
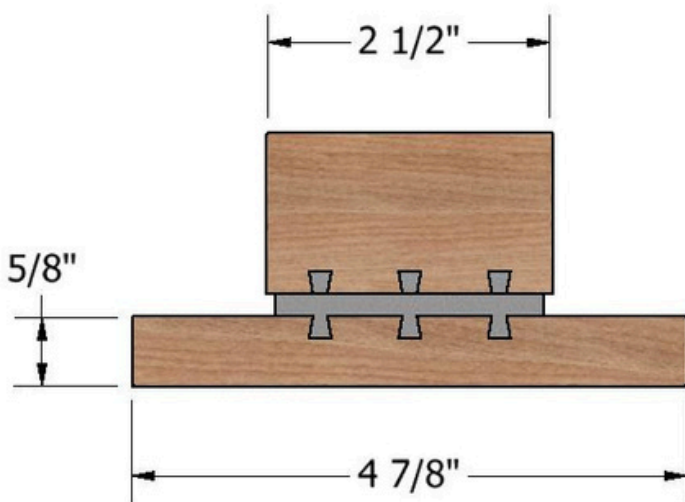

Attaching HushFrame decoupling connectors to the structure

Attach each decoupling connector to the structure with **TWO (2)** fasteners through the legs of the decoupling connector as shown below, one on each side of the furring mount. We specify 1-5/8" course-thread bugle-head screws, OR alternatively, min. 1-1/2" long, medium crown staples, OR, min. 6p ring shank sheathing nails.

NO ADHESIVES OF ANY SORT SHOULD BE USED



1-5/8"



1-1/2"



6p



Mounting alignment

Be sure to align the long axis of the decoupling connectors with the front face edges of the studs or joists. The structure mounts should sit flush with or slightly in front of this edge to ensure the furring mount face maintains a minimum projection of 3/16" beyond the stud or joist face plane. (see illustration) Failure to observe this rule risks incidental contact of the back of the furring with the framing face which will short-circuit the decoupling by allowing the noise to cross directly through the assembly and render the installation ineffective.



This decoupling connector is set slightly in front of the stud face guaranteeing no contact between the furring and the stud face



This decoupling connector is set too far back from the stud face... this will allow contact between the furring and the stud which will kill the noise reduction



It's the gap between the furring and the framing members that is the decoupling... noise can't jump across the gap so it has to travel through the decoupling connector on its path where it gets caught in the Vi-Bridge silicone core and goes no further

Note the Gap →



minimum 3/16"
Decoupling gap

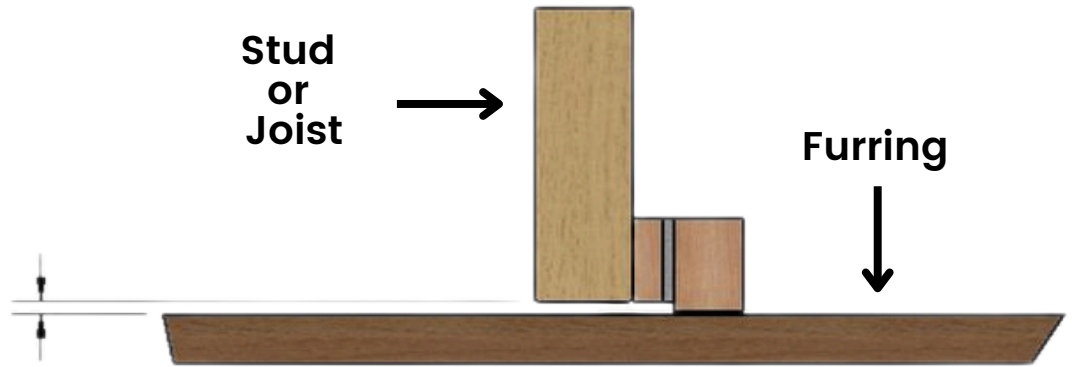

Be careful to properly position the decoupling connectors on the framing

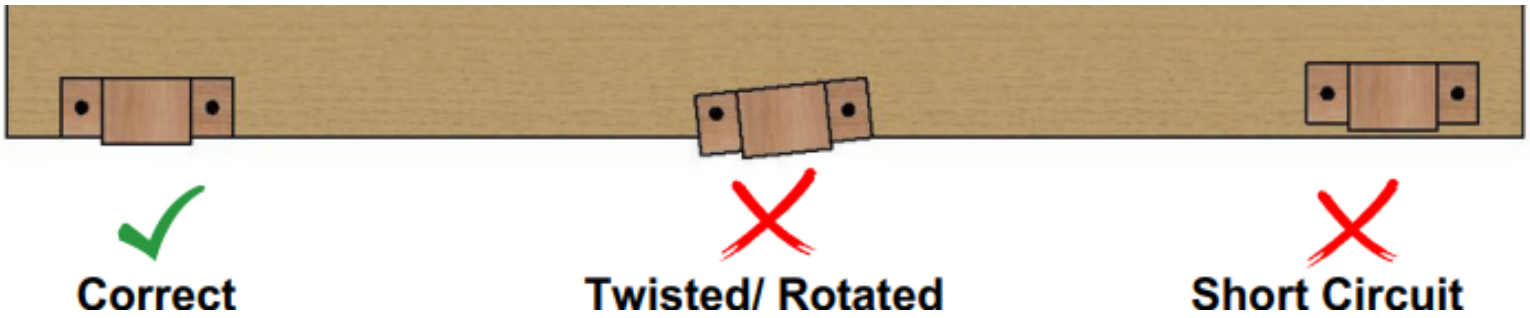

HushFrame decoupling connectors must be installed square and plumb on the framing members. Any warped or twisted framing must be corrected with shim material to ensure correct decoupling connector positioning.

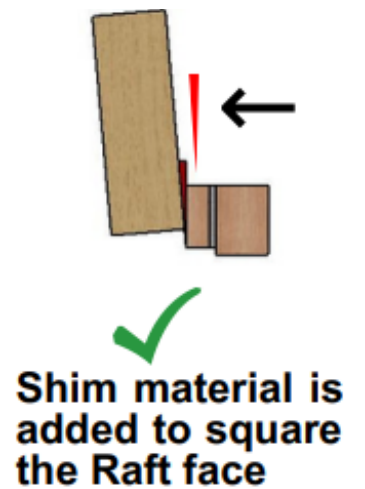
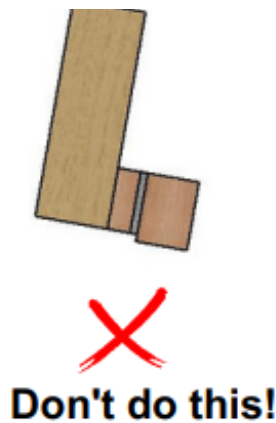
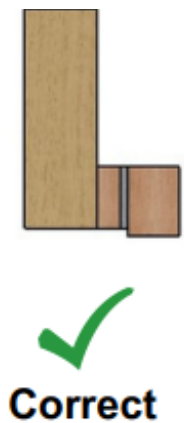

No twisting of the decoupling connectors is permitted

Decoupling connectors are very robust when properly installed and are designed to provide superior shear or tension loading strength.

CRITICALLY IMPORTANT:

Decoupling connectors are not designed to resist rotational forces and must not be subjected to twisting. (see illustration) All initial furring attachment must ensure that no individual Raft is subjected to damaging stresses where the leverage of the unfastened length of a furring strip is allowed to hang or dangle beyond the initial Raft connections. Both ends of the furring must be held securely until fastened to the respective decoupling connectors.

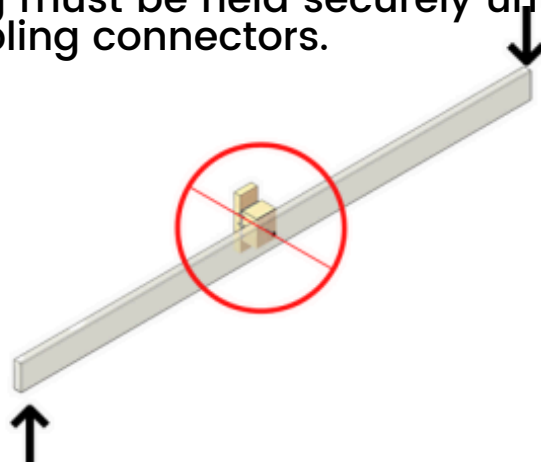

**DO NOT ROTATE
DECOUPLING CONNECTORS!**

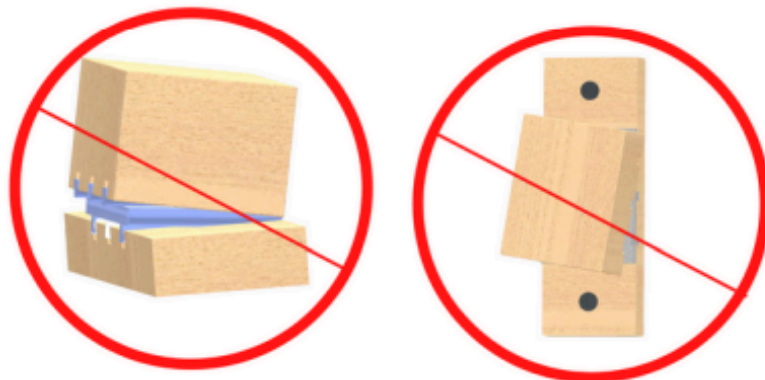

**THE DECOUPLING CONNECTORS ARE
BUILT FOR SHEAR AND TENSION LOADING
ONLY**



Assembly surface must be flat

It is **essential** that the surface plane of the installed decoupling connectors be flat. Walls can be out of plumb and ceilings can be sloped, those conditions are not necessarily a problem, but the mounting plane for the furring **must be flat**.

This is a major concern, particularly when installing HushFrame during remodeling where old studs and joists have settled, twisted, and deflected. But it's also important to keep a watchful eye on this with new construction framing.

We recommend that the installer run string lines or a laser alongside the furring runs to check for conformity. Stud or joist faces that fall behind the plane of the studs or joists on either side can be corrected in one of two ways; 1.) the HushFrame decoupling connectors can be moved forward on studs or down on joists so the mounting faces protrude beyond the structural plane by as much as $\frac{3}{4}$ " to close the gap, or 2.) shim material can be sandwiched between the decoupling connectors and the furring to flatten it prior to fastening. (see illustrations on the next page)

Not a flat assembly surface - *Do Not Do This!*



Rafts are moved forward to correctly flatten the plane...

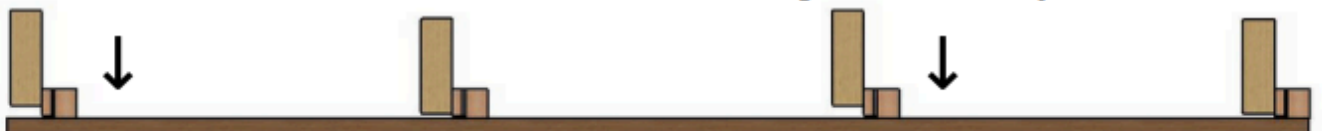

Or... shim material is added to correctly flatten the plane



Here you see the decoupling connectors have been positioned below the bottom of the truss cord faces to create a flat plane for the wood furring attachment and gypsum panel installation.



Attaching furring to the decoupling connectors

When attaching wood furring to the decoupling connectors, we specify one 2", or alternatively, two 1-5/8" course-thread bugle-head screws, located in the center 2/3rds of the decoupling connector.



For attaching optional metal hat channel, we specify two 1-1/4" fine-thread selftapping bugle-head screws, one inserted through each shoulder at a 45-degree inward angle

Do Not attempt to attach wood furring to the decoupling connectors with a pneumatic nail gun or utilizing oversized screws, these will destroy the decoupling connectors.

Only straight, flat, structurally solid dimension lumber should be used as wood furring. Nominal 1x3 is a common dimension, but 1x2 and 1x4 are also appropriate. Warped, checked, twisted, or split boards must not be used. (see illustration) Utilizing heavier dimension lumber for furring, such as 2x3 and 2x4 is not appropriate without detailed consultation with the factory technical staff. Similarly, certain special applications call for attachment of plywood panels directly to the decoupling connectors without intermediate furring attachment. Such special applications are beyond the scope of this guide and should be directed to the factory technical staff.

Furring splices should be made between the decoupling connectors



Wood furring installed on the ceiling.



Wood furring installed on the wall.



Furring placement positioning

Furring is typically attached in rows that run perpendicular to the face of the studs or joists in an assembly as shown in the spacing and loading charts found at the end of this guide. The ends or sides of furring rows should not contact the adjacent assembly components. Leave a gap of at least 1/4" to avoid potential flanking paths and noise transit. This is particularly important for the top and bottom furring rows on wall installations and for the perimeter rows on ceiling installations.

Here you see the furring is properly spaced and there's no contact to the adjacent assembly.



While it is not an option with metal hat channel, there is also the option to install wood furring parallel to the framing members which would present the opportunity to recess the furring in the framing cavity to save space that would otherwise be lost. (see illustration) In this situation, care must be taken to prevent the furring strips from making contact with the top and bottom plates of wall assemblies. Where double bottom plates are installed, parallel recessed furring would likely be impractical due to the length of unsupported gypsum panel at the bottom of the wall.

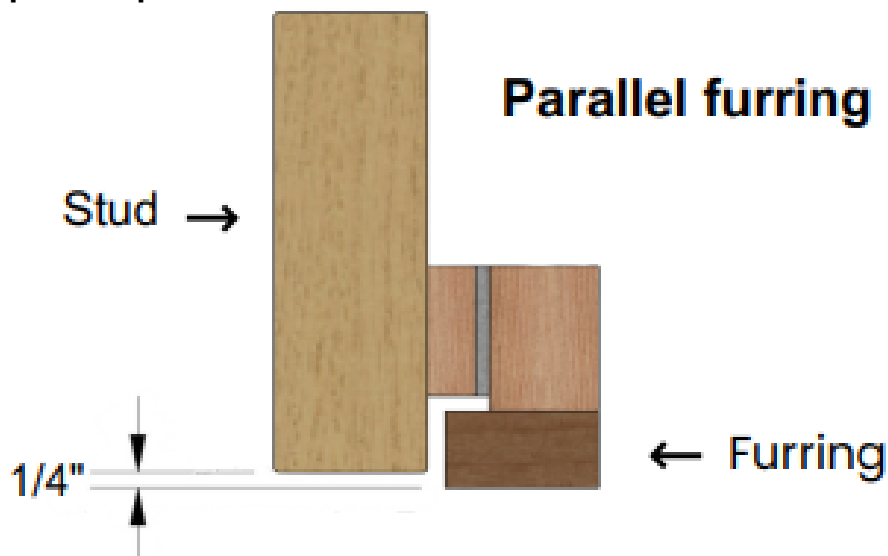

Baseboard backer is typically 1x3 or 1x4 furring installed behind the bottom of the gypsum wall panels and attached to HushFrame decoupling connectors that are mounted along the top of the bottom plates at the interior of the stud cavities as opposed to decoupling connectors that are mounted along the sides of the studs. (see illustration)

In this illustration decoupling connectors are mounted on the bottom plate

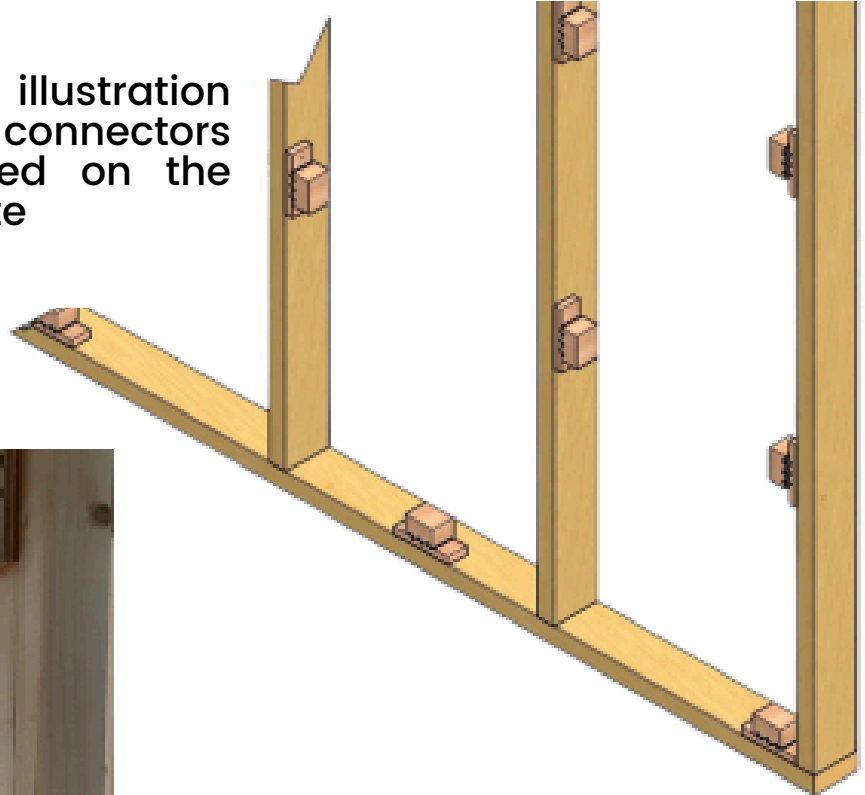

These two photos show the decoupling connectors mounted on the bottom plate supporting the baseboard backer



Mechanical attachments

HushFrame decoupling connectors are the only decoupling products that work with wood furring. Not only saving you the extra cost and burden of metal channel, but allowing you to attach all mechanical devices to the decoupled wood furring, not the structural studs or joists, on the decoupled side of the walls or floor/ceilings.

Why is this important? Because devices attached to the wood furring don't allow short circuiting and flanking paths for noise, a major drawback for metal channel that requires all mechanicals to be attached to the structure, helping noise get through.

In this photo of the decoupled side of this wall, you can see a section of furring was added supported by a small length of 2x4 connecting two rows of furring so the electrical box can be attached and decoupled. The other electrical box in view is attached directly to the stud on the non-decoupled side of the wall.



In this photo of the non-decoupled side of this wall, you can see the section of 2x4 added behind and connecting the two rows of furring so the added section of furring meets the face plane of the furring rows. The other electrical box in view is attached directly to the stud on this, the non-decoupled side of the wall.



Here again you can see the added section of furring to accommodate the electrical box on the decoupled side of this wall.

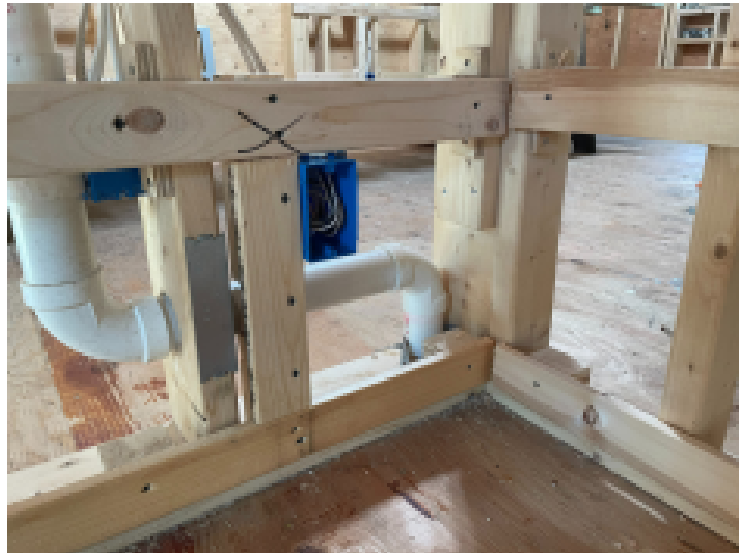

There's a lot going on in this section of the wall. On this non-decoupled side, the plumbing vent pipe the support strap and the hanger are all connected to the structural wall components and not contacting the back side of the decoupled furring.

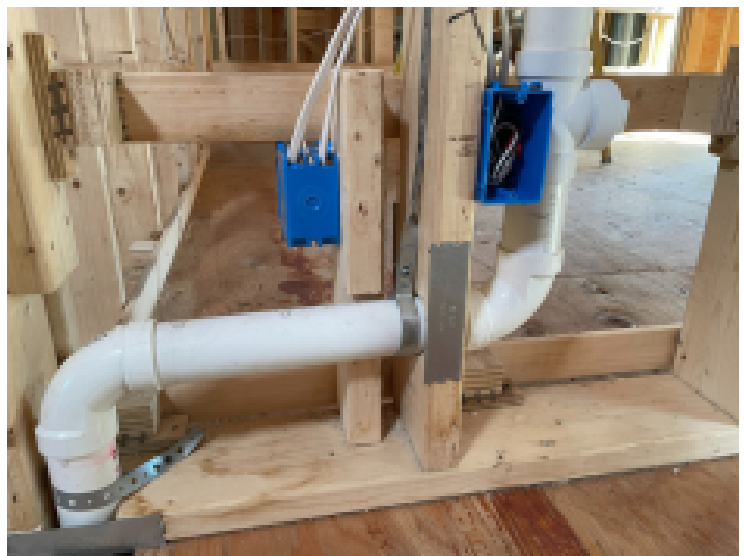

Another strategy is to add an additional row of decoupled furring to accommodate electrical box mounting at a chosen height.



It's very important that all the mechanicals in the ceiling be attached directly to the decoupled furring to ensure the most effective noise control.

In the picture below you can see a bathroom exhaust fan, an HVAC register box, and a recessed light fixture rough-in plate, all correctly attached to the furring.



Speaker box rough-ins, fire alarm junction boxes, light cans...
Everything attaches to the decoupled furring.



Install the furring early

Once the framing has been completed, it's best to next install the HushFrame decoupling connectors and wood furring prior to the installation of mechanicals such as electrical boxes, exhaust fans, and HVAC ducts and registers. To prevent short circuiting and the creation of flanking paths which compromise the acoustic performance, these mechanicals should be attached to the wood furring and not to the sides of studs and joists.

Non-bearing partitions go under the decoupled furring

To ensure the most effective noise reduction in floor/ceilings, where possible, install the HushFrame decoupling connectors and furring once the bearing walls and floor joists are in place and then build the non-bearing partitions underneath, attaching the wall top plates to the underside of the furring. This will prevent floor/ceiling noise from crossing into the wall assemblies.



Furring spanning dense headers and jambs

There are situations where framing spacing is too tight to accommodate the mounting of every decoupling connector located along a furring row as detailed in this installation guide, such as with furring that spans across dense headers or terminates with unsupported ends across fat jamb construction at doors and windows. In this situation the furring is attached to as many decoupling connectors as possible to maintain the installation grid. Missing decoupling connectors are substituted by drilling a 3/8" hole through the furring and extending into the framing behind by 3/4". Ensure the furring is temporarily secured 1/4" +/- from the face of the framing member and inject silicone paste through the hole in the furring so it floods into the frame hole and creates a small mass between the two. (see illustration) Allow the silicone to cure undisturbed for at least 24 hours.

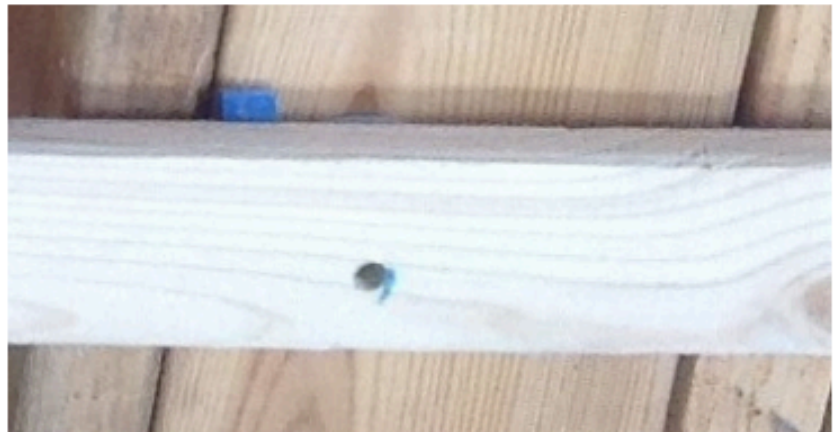

Metal stud applications

HushFrame decoupling connectors outperform the others when installed on metal framing also, not just wood studs and joists.

Like you see here in the framing of studio production sound stage demising walls.

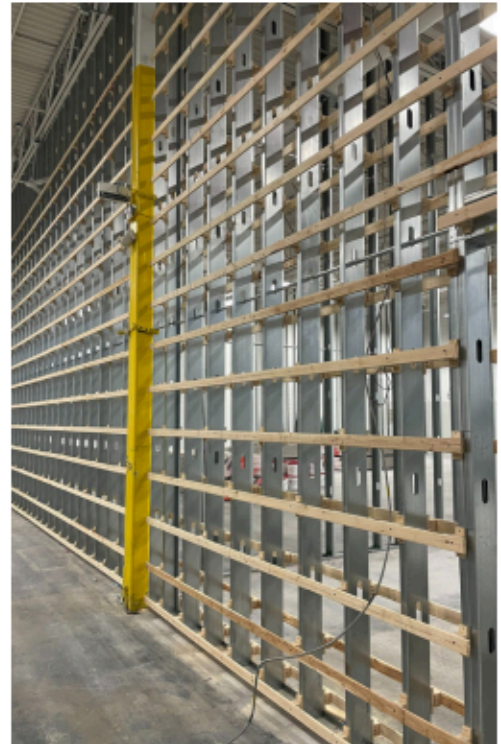
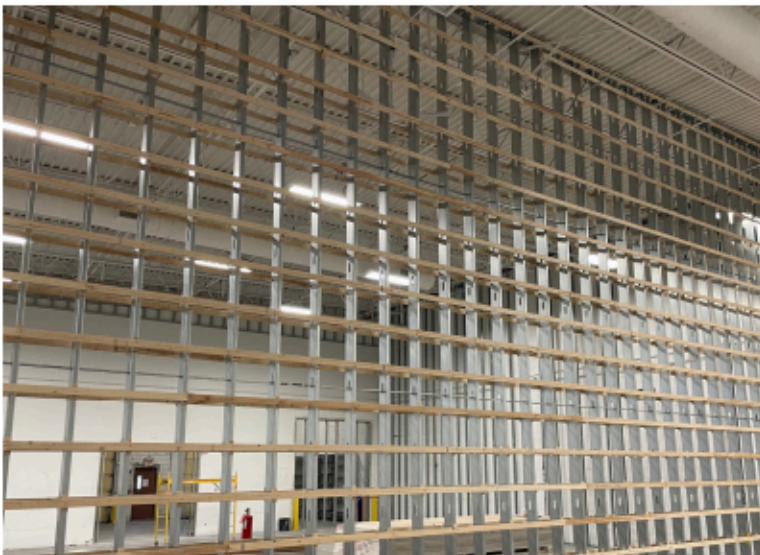

Use soft cavity insulation

To eliminate what is known as “Air Spring”, where noise resonates and thrives in uninsulated stud bays and joist cavities, it is necessary to install some soft insulation material. Nothing outperforms common unfaced fiberglass batt insulation in the acoustic test laboratory. Blown-in cellulose is also a top performer and can effectively fill those difficult-to-access voids. Once the air spring is managed, the noise vibration energy travels through the structural frame components, and the HushFrame decoupling connectors defeat that movement.

This is not to say that specifically marketed 'acoustic' insulation products are problematic, just simply not advantageous in a HushFrame decoupled assembly.

Avoid dense materials and rigid insulation at all costs

Beware of dense insulation materials such as mineral fiber and furnace slag-based products that are marketed as superior acoustic insulation. When very dense materials are stuffed into stud and joist cavities, they can create a “bridge” that actually helps noise energy move across the space. Under no circumstance should rigid insulation be substituted for soft material in building assemblies requiring acoustic attenuation.



Hold gypsum panels a minimum of 1/8" from adjacent components

When installing gypsum panels onto the furring, avoid allowing the panels to make contact with adjacent assemblies. Wall panels should not contact ceiling framing or panels and ceiling panels should not contact wall framing or panels. Allow a gap of 1/8" or 3/16" in these intersections to prevent noise vibration that is moving through one assembly from simply crossing over to an adjacent one. Sliding the tips of shim shingles against the ends of the gypsum panels when installing is a quick and simple way to ensure proper spacing.

Fill gaps with non-hardening caulk

Prior to finishing the gypsum panels with tape and joint compound, the various assembly intersection gaps should be filled with a non-hardening caulking that serves to prevent noise migration. Pure latex caulking is not appropriate due to its rigid composition once dried. A latex caulking that contains a percentage of silicone, readily available at the big box stores, can be used as well as any silicone product sold in tubes as caulking or sealant.

We also want to stress the importance of running that caulk bead along the bottom edge of the wall framing, where the bottom plate intersects with the wood subfloor or concrete slab. It's surprising how much noise crosses under that construction... 5 or 6 STC points can be lost by ignoring that intersection, really impacting the overall wall performance. Put a bead of caulking against the bottom plate along the floor and add a second bead of caulk under the gypsum panels when you hold them off the floor assembly by 1/8" - 3/16". It'll pay dividends in quiet.



Installation spacing patterns

HushFrame decoupling connectors are installed in grid patterns and the attached furring strips are fastened in rows typically spaced either 16" or 24" on centers beginning at the bottom of wall assemblies or from the side of ceiling assemblies. Row spacing can be reduced to 12" on center to accommodate extraordinary connected loading. The charts shown here are a general depiction of common installation patterns. For assemblies with studs or joists 16" on center, the most common patterns are furring rows 16" or 24" on centers and decoupling connectors spaced 32" along the length of the furring, mounted on every other stud in a staggered pattern. For assemblies with studs or joists 24" on center, the most common pattern is furring rows 24" on centers and decoupling connectors spaced 24" along the length of the furring.

For questions regarding concentrated loading situations or complex mechanical device attachment, please contact the factory technical staff.

1-800-809-4874





HushFrame Decoupling Connectors Installation spacing pattern 16-24-16

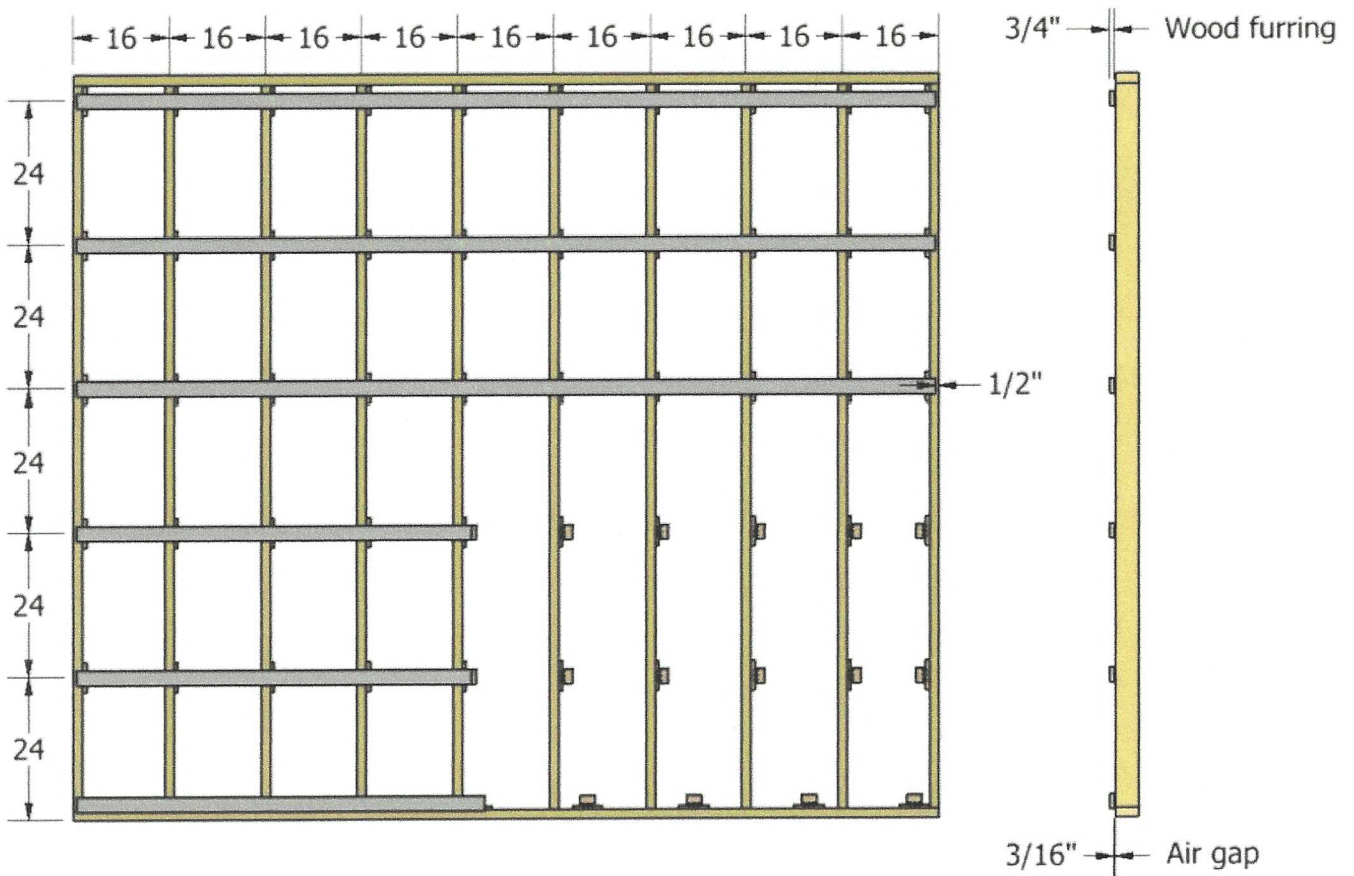

16" on center Wall Stud or Ceiling Joist Framing

16" on center rows of Wood Furring or Metal Hat Channel
HushFrame decoupling connectors installed 16" on center

Requires one decoupling connector per 2 sq. ft. of surface area
Recommended maximum attached load - 11 lbs. per sq. ft.
2 layers of 5/8" gypsum panels weigh 4.6 lbs. per sq. ft.



HushFrame Decoupling Connectors Installation spacing pattern 16-24-32

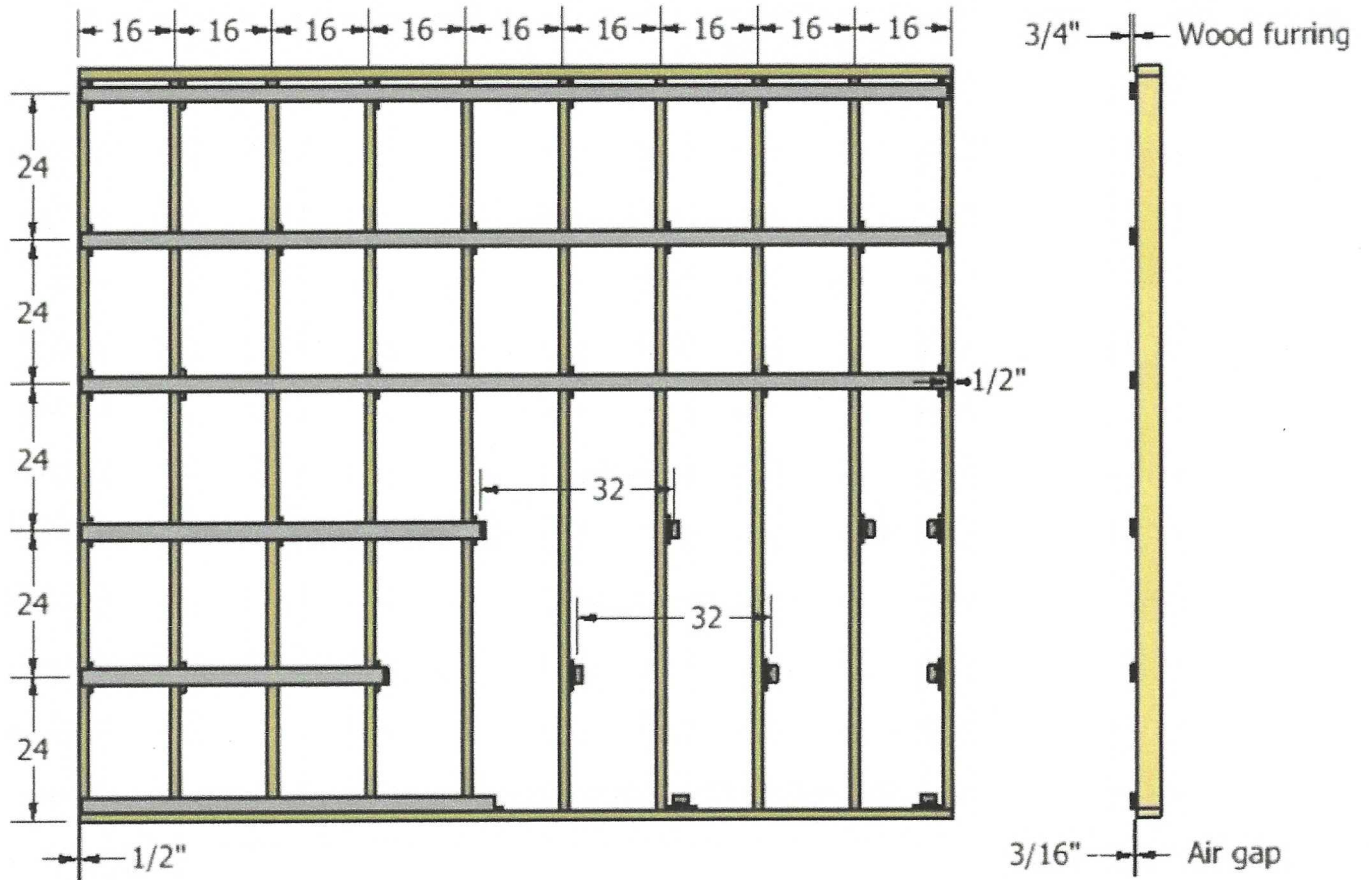

16" on center Wall Stud or Ceiling Joist Framing

24 on center rows of Wood Furring or Metal Hat Channel
HushFrame decoupling connectors installed 32" on center - staggered pattern

Requires one decoupling connector per 3.5 sq. ft. of surface area
Recommended maximum attached load - 6 lbs. per sq. ft.
2 layers of 5/8" gypsum panels weigh 4.6 lbs. per sq. ft.



HushFrame Decoupling Connectors Installation spacing pattern 24-16-24

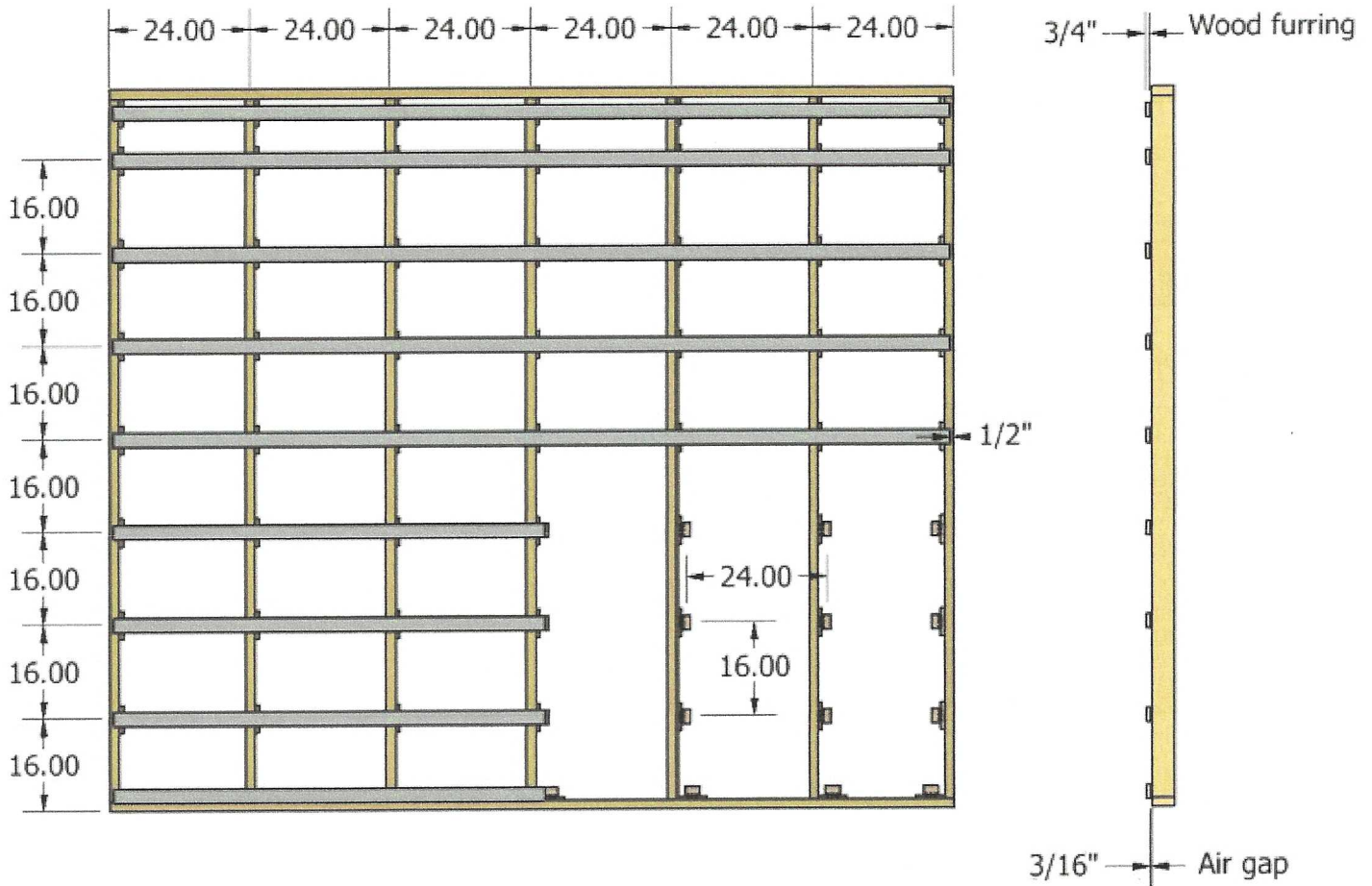

24" on center Wall Stud or Ceiling Joist Framing

Rows of Wood Furring or Metal Hat Channel - 16" on center
HushFrame decoupling connectors installed 24" on center

Requires one decoupling connector per 2 sq. ft. of surface area
Recommended maximum attachment load - 11.5 lbs. per sq. ft.
2 layers of 5/8" gypsum panels weigh 4.6 lbs. per sq. ft.



HushFrame Decoupling Connectors Installation spacing pattern 16-16-32

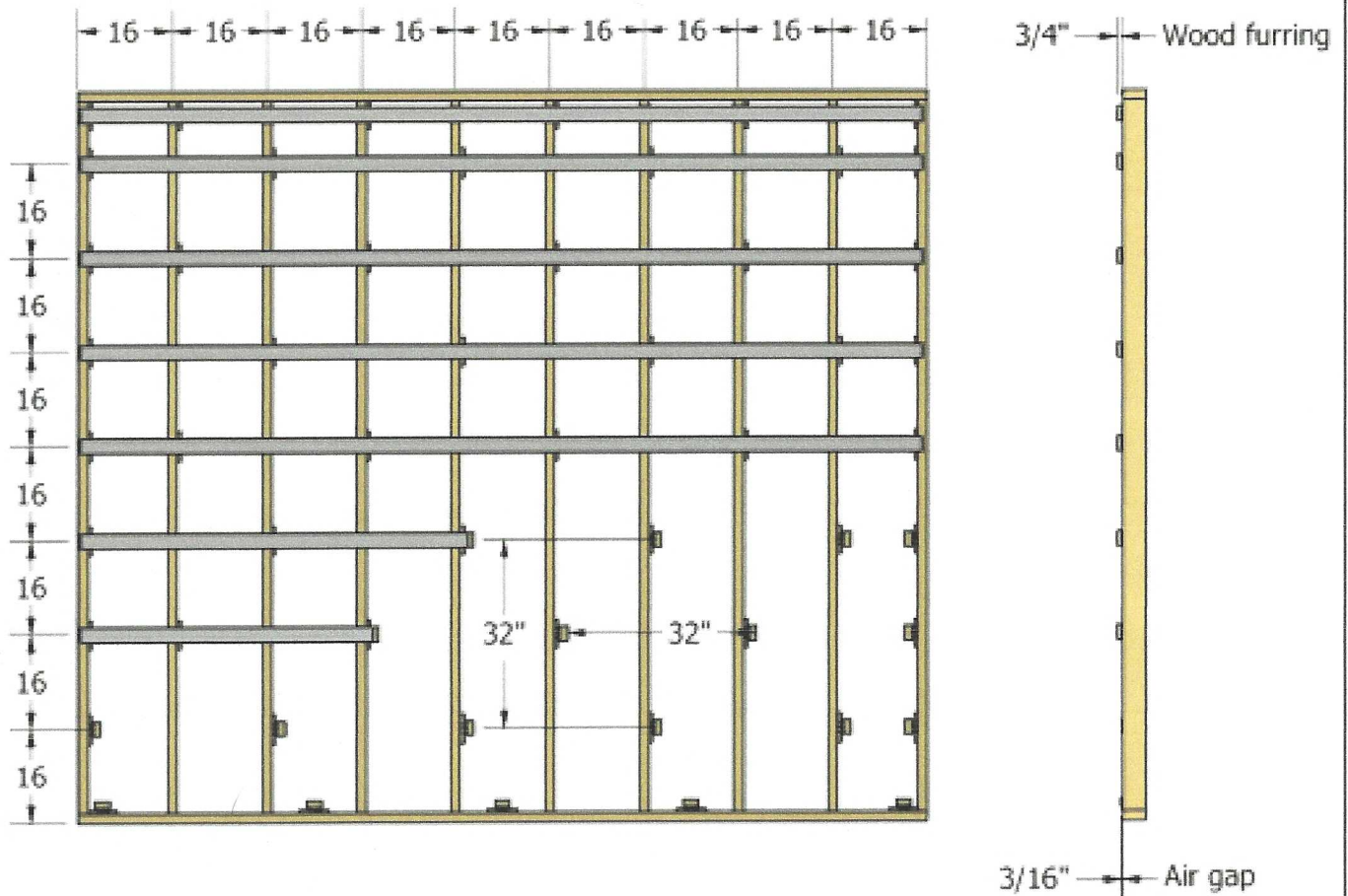

16" on center Wall Stud or Ceiling Joist Framing

Rows of Wood furring or Metal Hat Channel - 16" on center
HushFrame decoupling connectors installed 32" on center

Requires one decoupling connector per 2.4 sq. ft. of surface area
Recommended maximum attached load - 9 lbs. per sq. ft.
2 layers of gypsum panels weigh 4.6 lbs. per sq. ft.



HushFrame Decoupling Connectors Installation spacing pattern 24-24-24

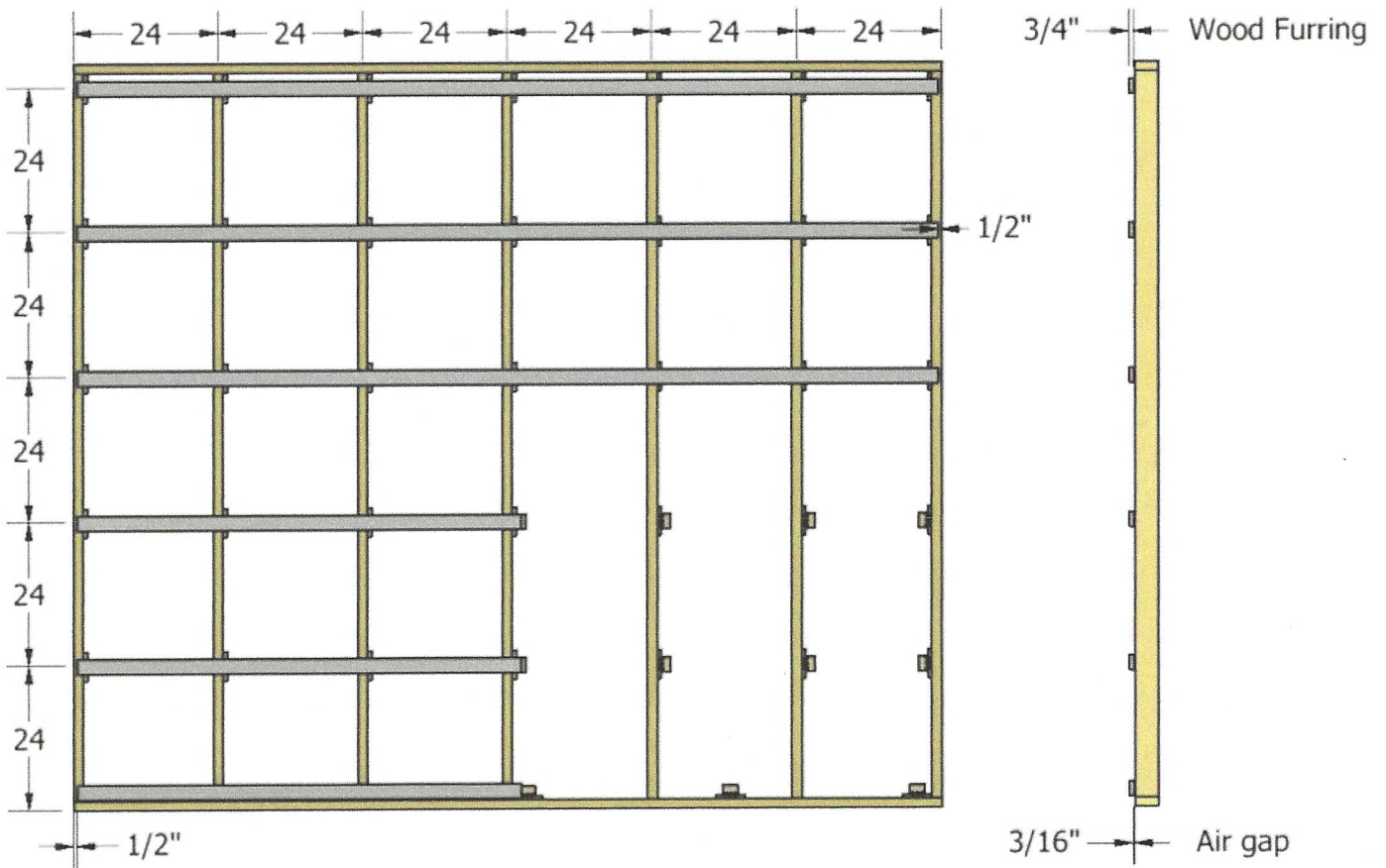

24" on center Wall Stud or Ceiling Joist Framing

Rows of Wood Furring or Metal Hat Channel - 24" on center
HushFrame decoupling connectors installed 24" on center

Requires one decoupling connector per 3 sq. ft. of Surface area
Recommended maximum attached load - 7.5 lbs. per sq. ft.
2 layers of 5/8" gypsum panels weigh 4.6 lbs. per sq. ft.